

Mod.4850-95 A

01.01.2003

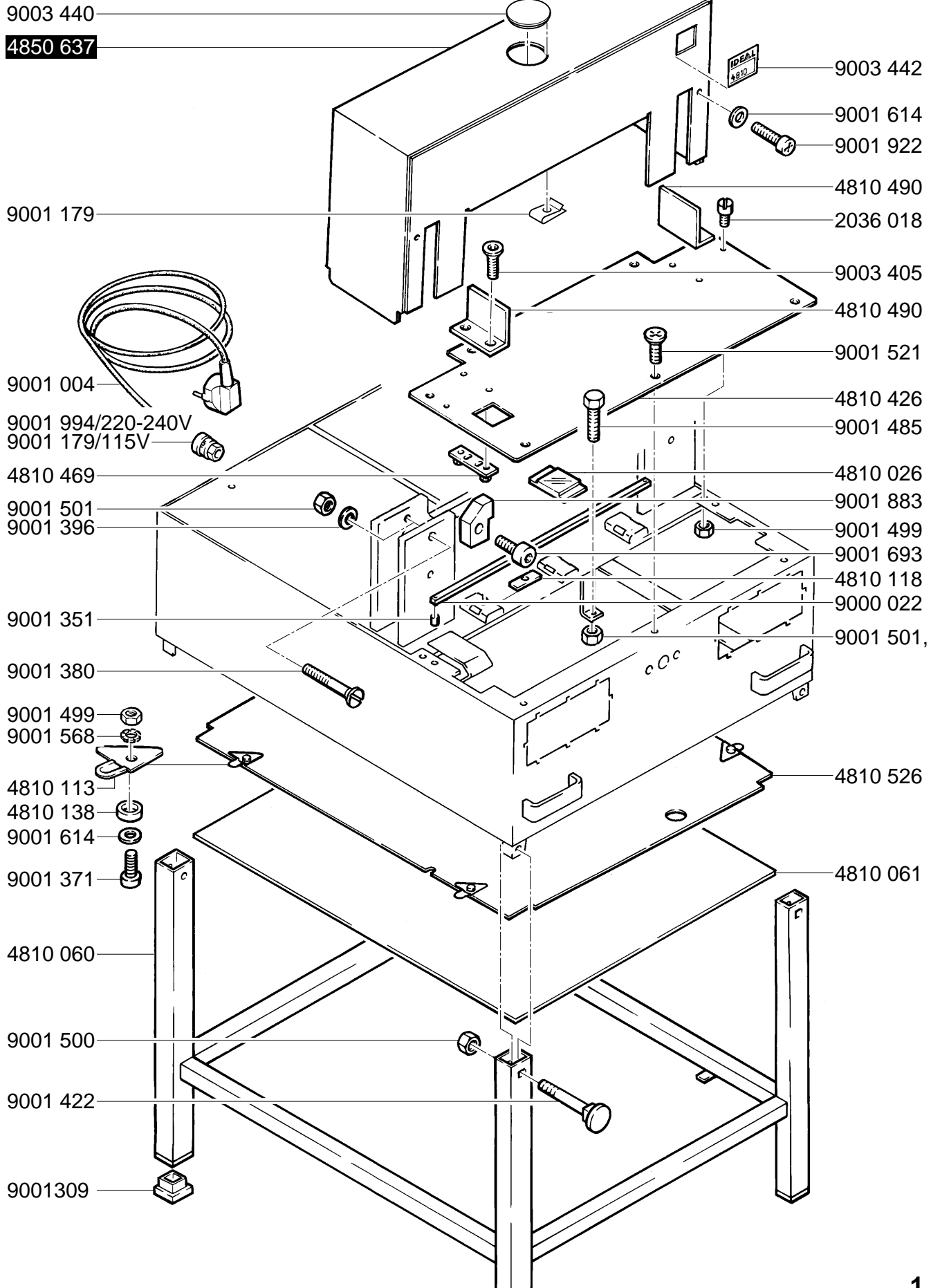

Mod.4850-95 A

01.01.2003

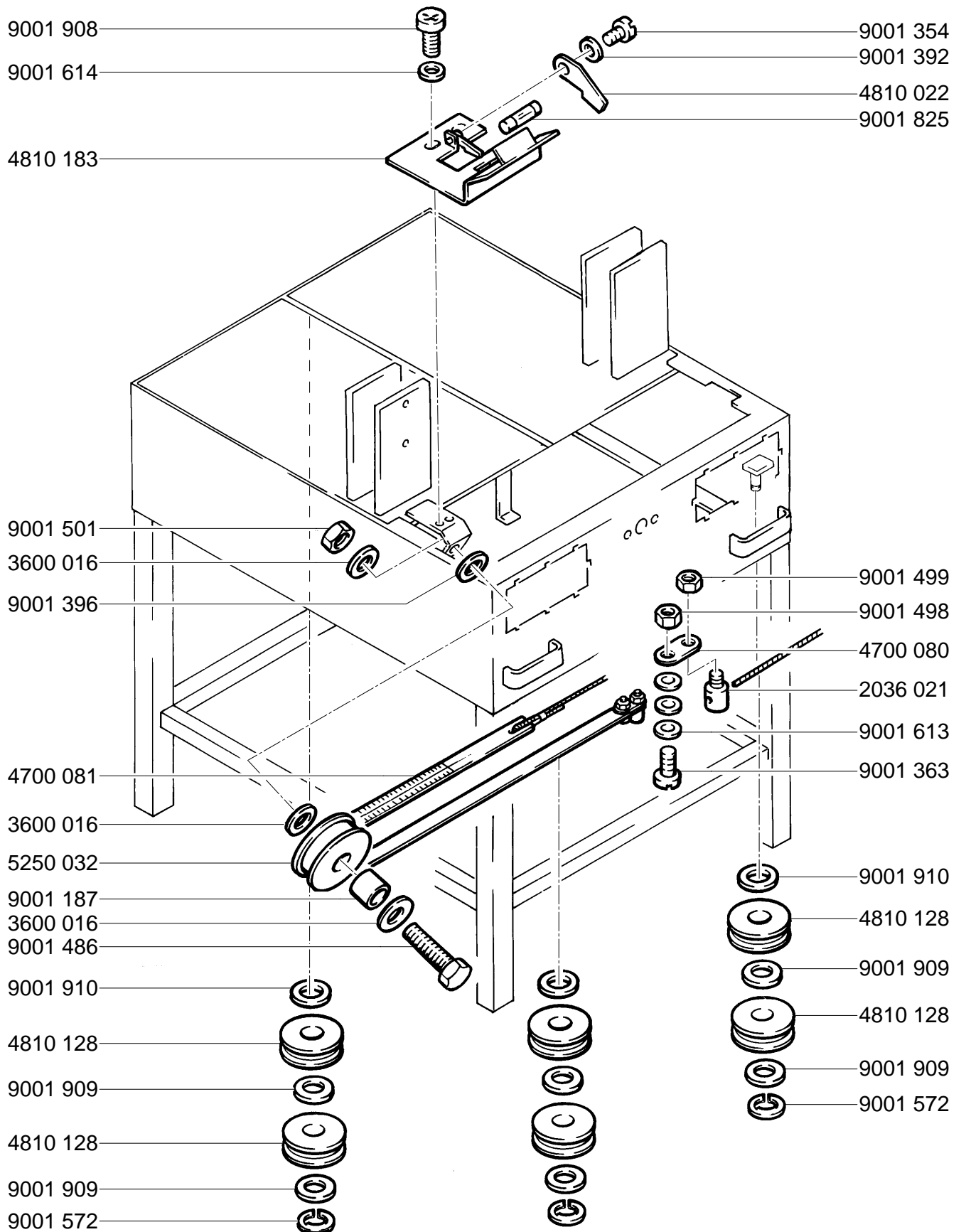

Mod.4850-95 A

01.01.2003

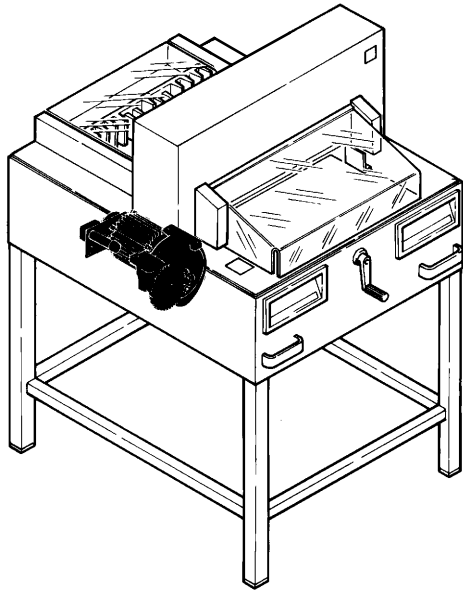

4810 540/220-230V/50Hz
4810 542/240V/50Hz
4810 541/115V/50Hz

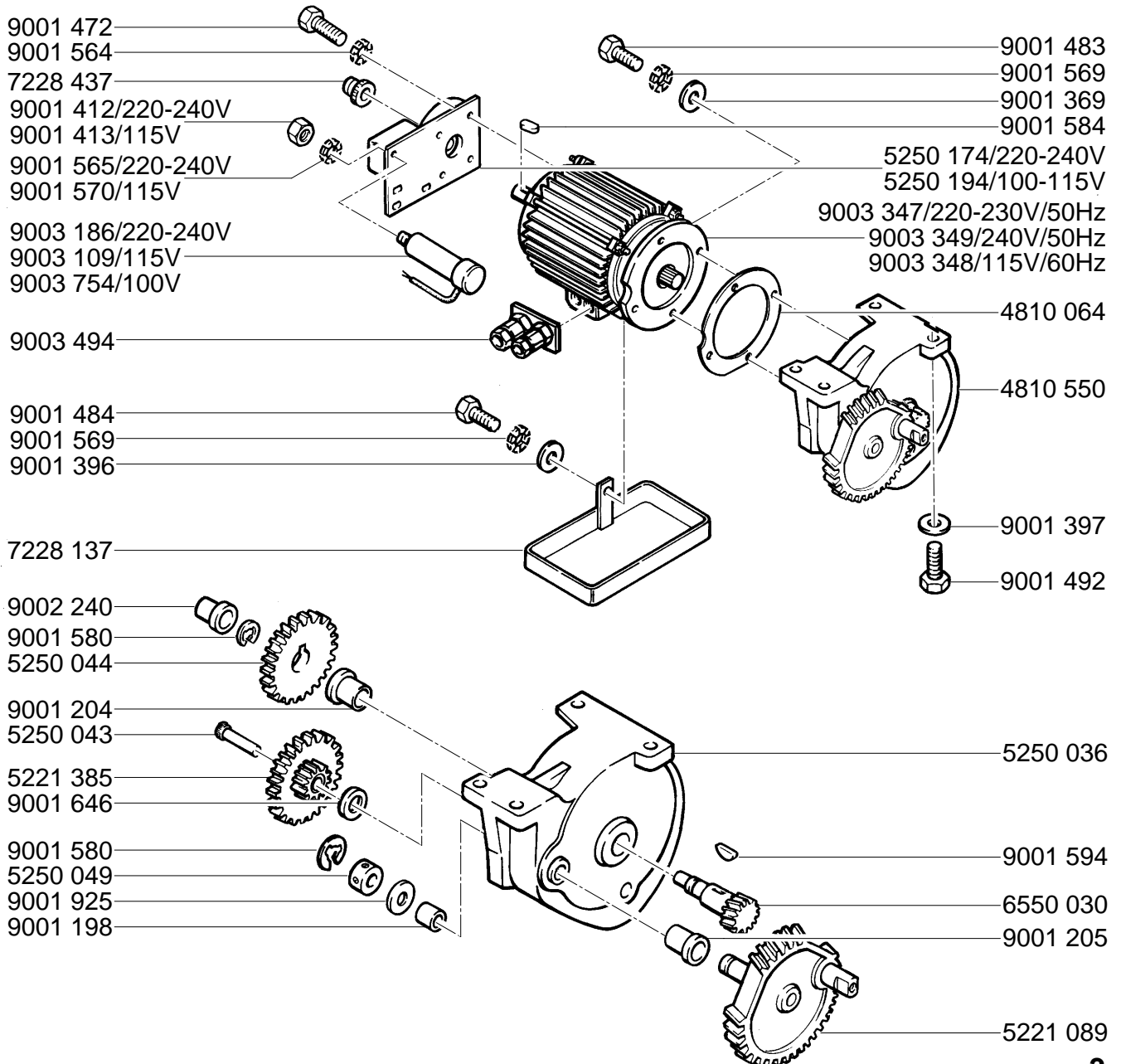
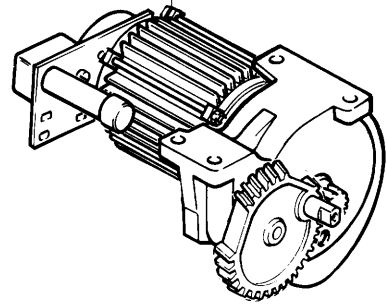

Mod.4850-95 A

01.01.2003

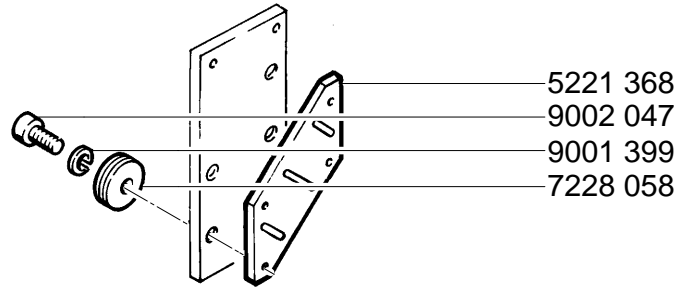
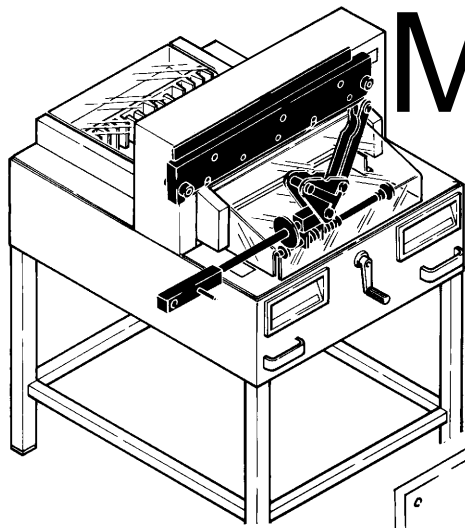

- 9002 047
- 9001 399
- 7228 058
- 5221 368
- 9002 135
- 5221 039
- 9003 001

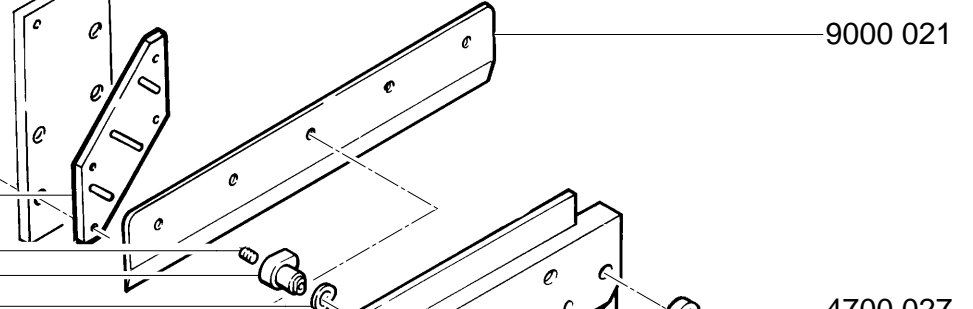

- 4810 429
- 4700 027
- 5221 044
- 4810 442

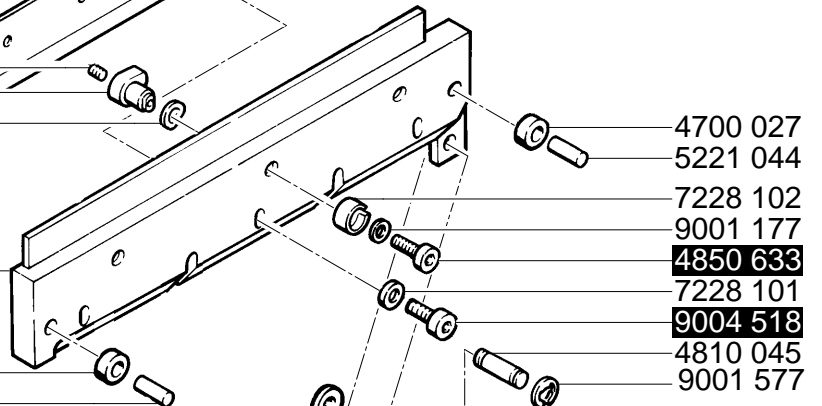

- 5221 050
- 5221 055
- 9002 408
- 4810 035

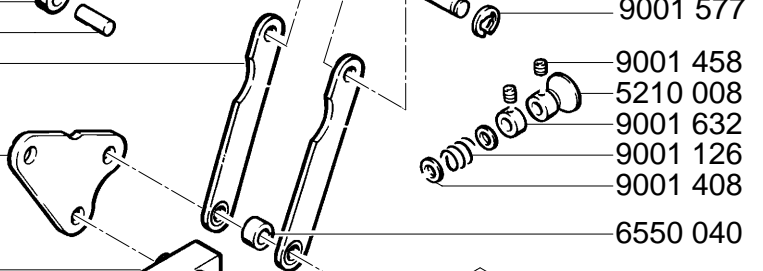

- 4810 122
- 4810 112
- 4810 037
- 9001 195
- 5221 059
- 9001 414
- 9001 564
- 9001 472

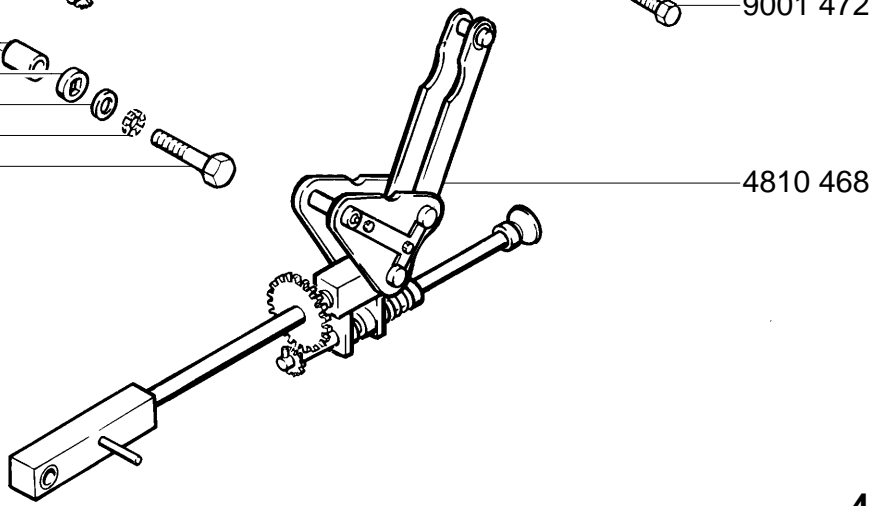
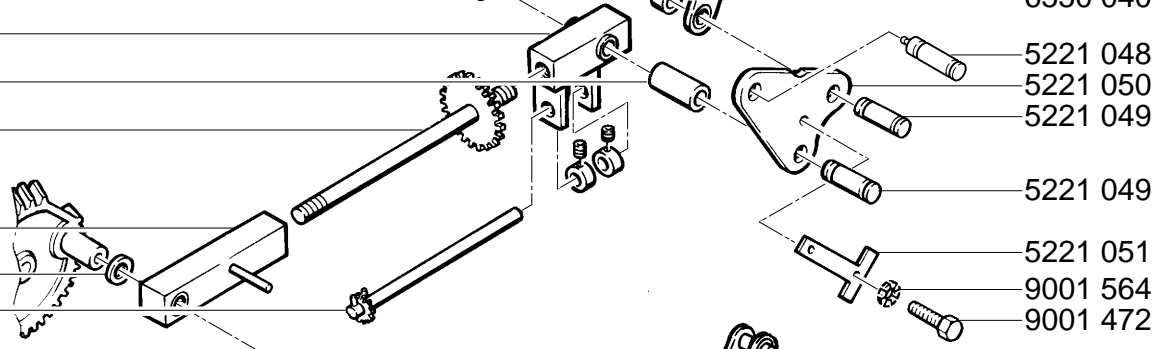

Mod.4850-95 A

01.01.2003

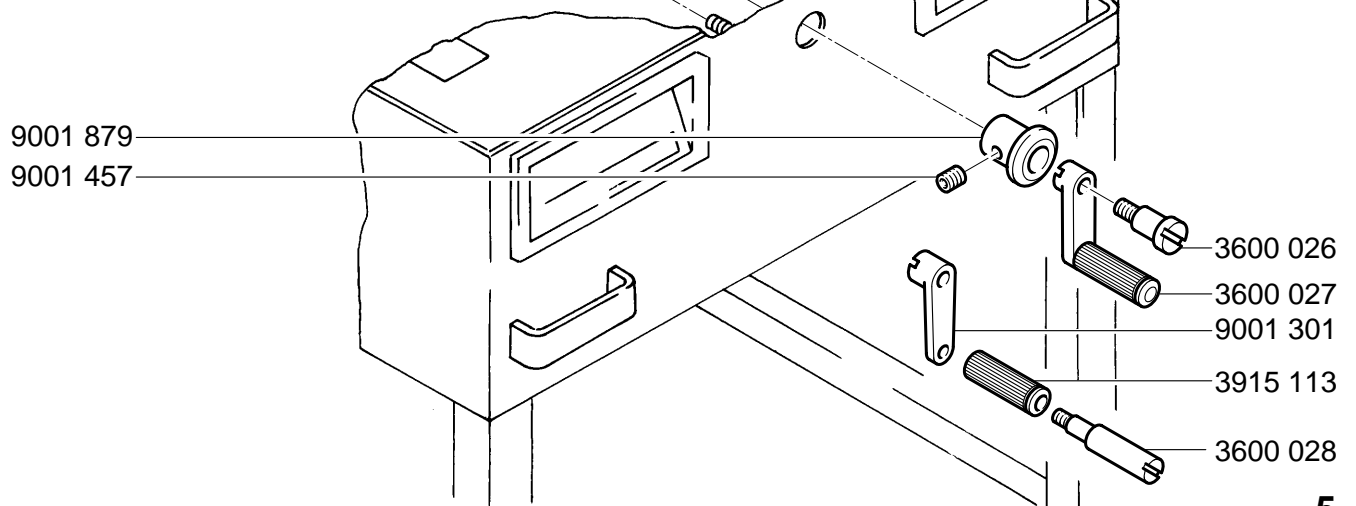
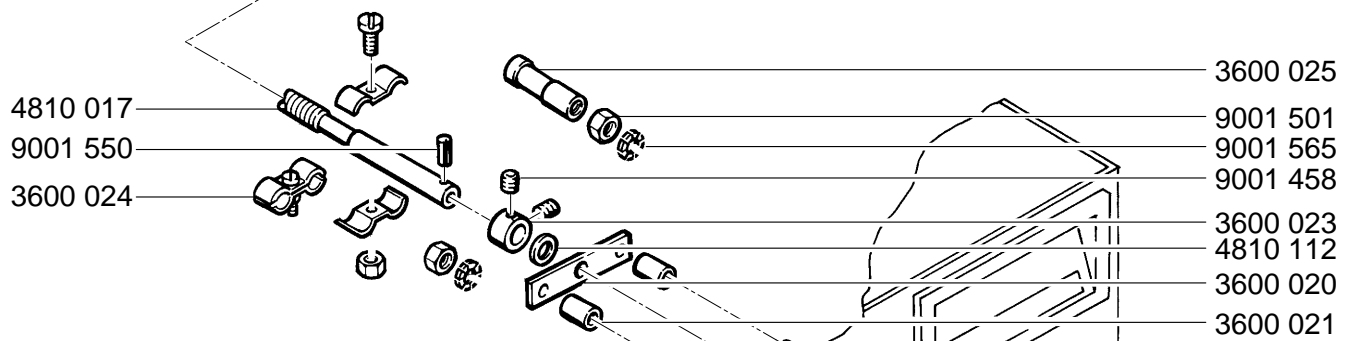
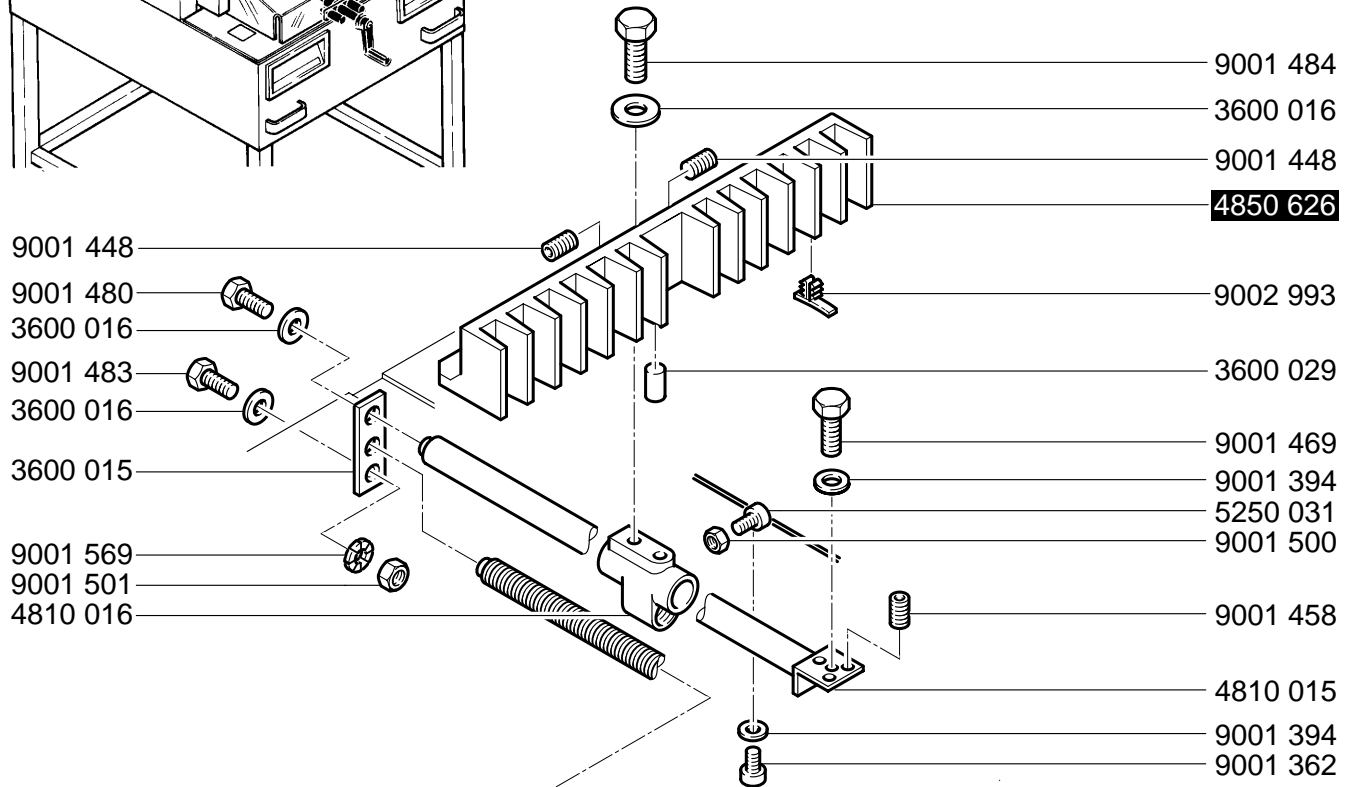
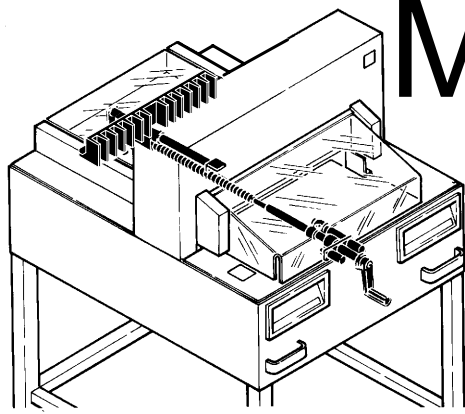

Mod.4850-95 A

01.01.2003

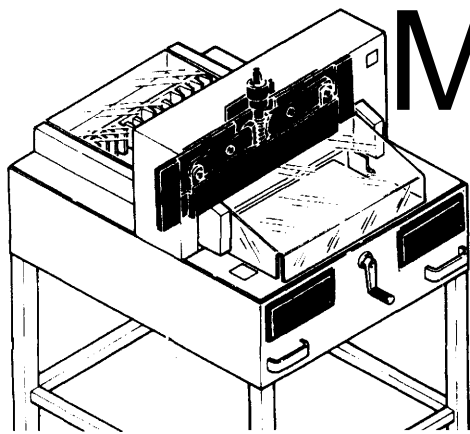

- 9001 417
- 4850 023
- 9001 594
- 6550 059
- 9001 136
- 9001 214
- 9001 616

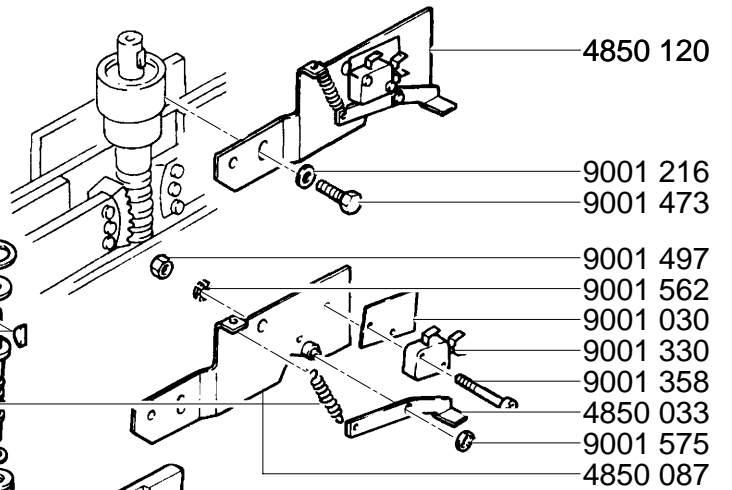

- 4850 120
- 9001 216
- 9001 473
- 9001 497
- 9001 562
- 9001 030
- 9001 330
- 9001 358
- 4850 033
- 9001 575
- 4850 087

- 9002 240
- 4850 008
- 5250 119

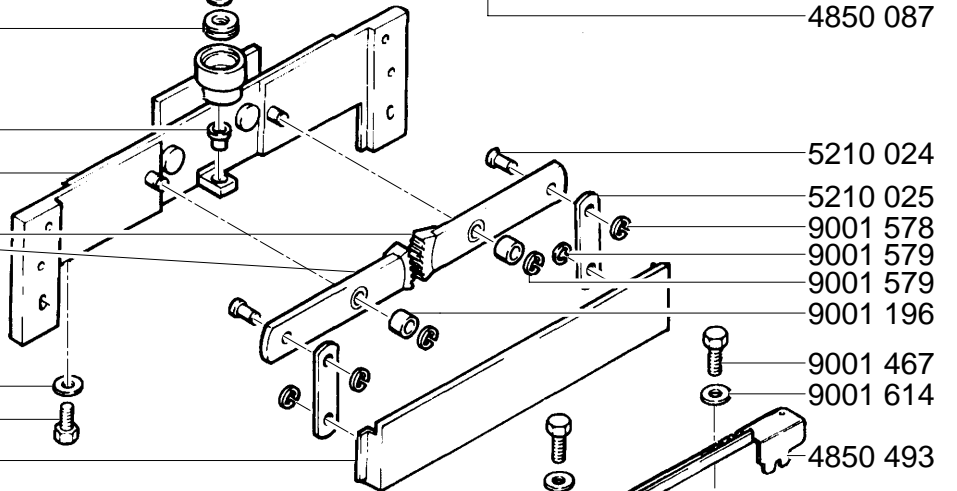

- 5210 024
- 5210 025
- 9001 578
- 9001 579
- 9001 579
- 9001 196
- 9001 467
- 9001 614
- 4850 493

- 9001 614
- 9001 467
- 4850 627**

- 9001 485
- 4202 099
- 4850 052

- 4850 628**
- 5221 270

- 9001 596
- 9001 485
- 4202 099
- 4850 052

- 9001 480
- 3600 016
- 5221 270

- 9001 498
- 9001 613

- 9002 536
- 9001 340

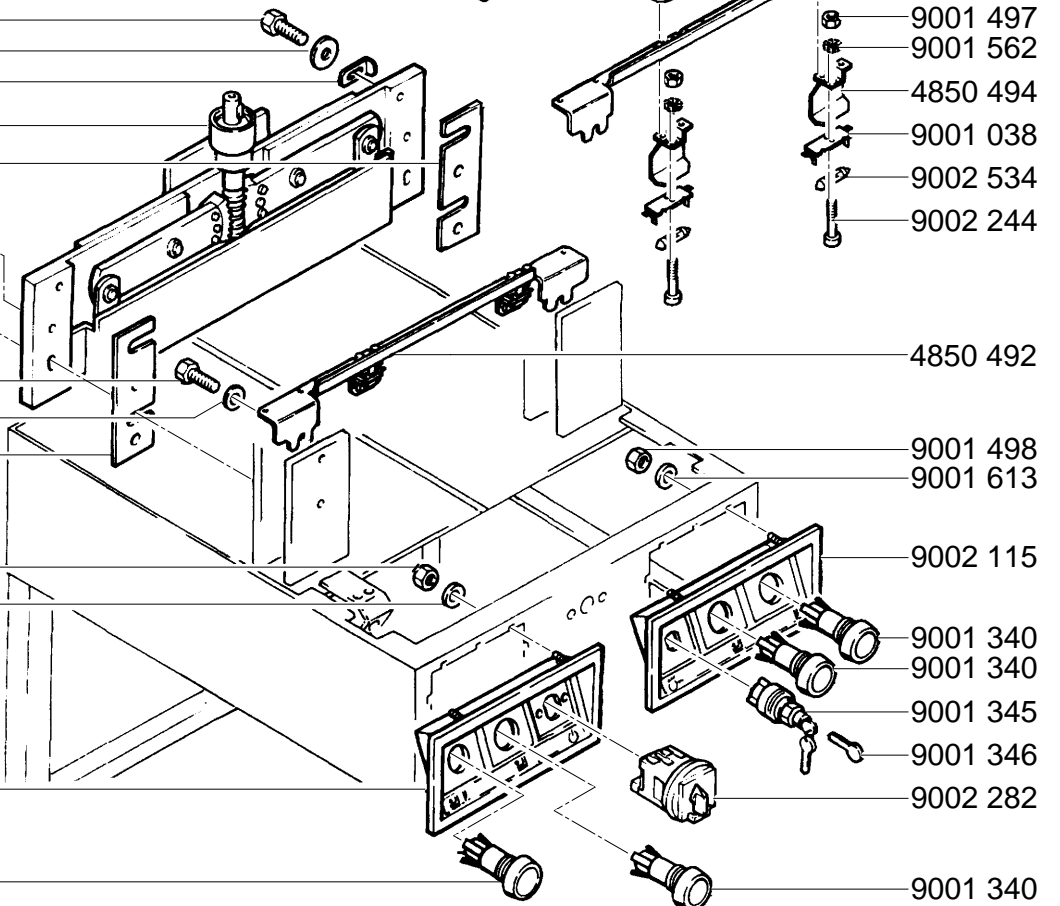

- 9001 497
- 9001 562
- 4850 494
- 9001 038
- 9002 534
- 9002 244
- 4850 492
- 9001 498
- 9001 613
- 9002 115
- 9001 340
- 9001 340
- 9001 345
- 9001 346
- 9002 282
- 9001 340

Mod.4850-95 A

01.01.2003

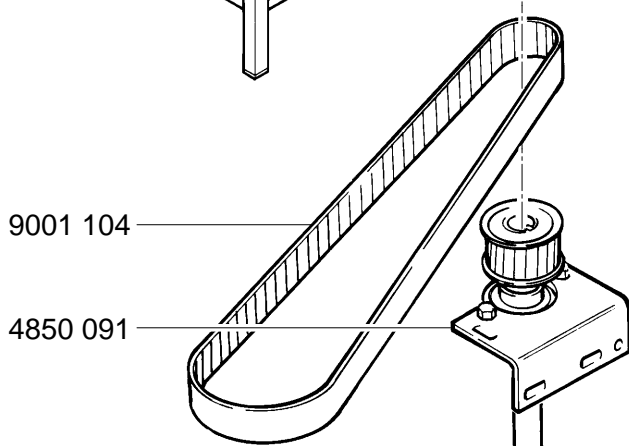
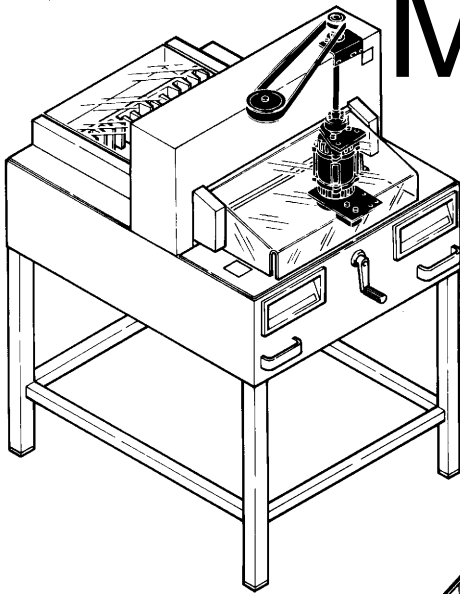

9001 104

4850 091

4202 027

9001 641

4850 010

9001 458

5250 062

4850 032

9001 445

9001 057/220-240V

9001 056/115V

4851 491

4850 046

5250 174/220-240V

5250 184/115V

4850 092/220-240V

4850 093/115V

9001 261/220-240V

9001 265/115V



9001 565

9001 412

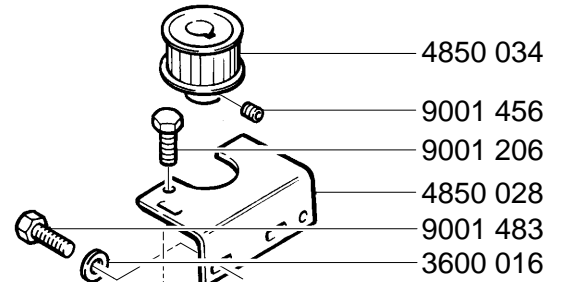
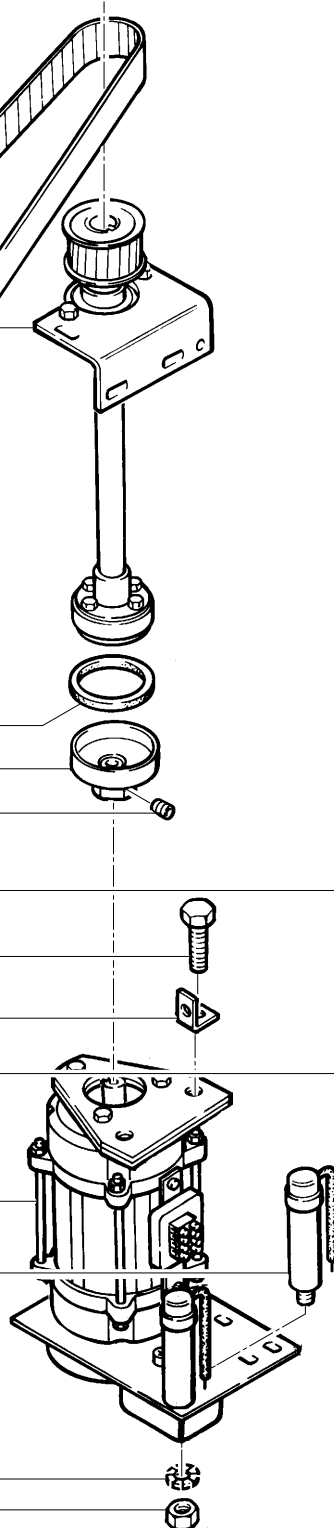

4850 034

9001 456

9001 206

4850 028

9001 483

3600 016

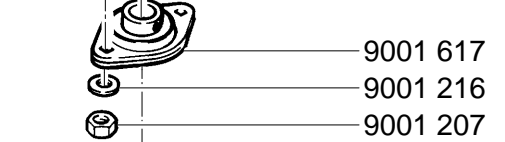

9001 617

9001 216

9001 207



9001 712



9001 474



4850 029



9001 216



9001 593



5250 057

9001 445



4850 047



9001 584



9001 584

7228 437

9001 564

9001 472

Mod.4850-95 A

01.01.2003

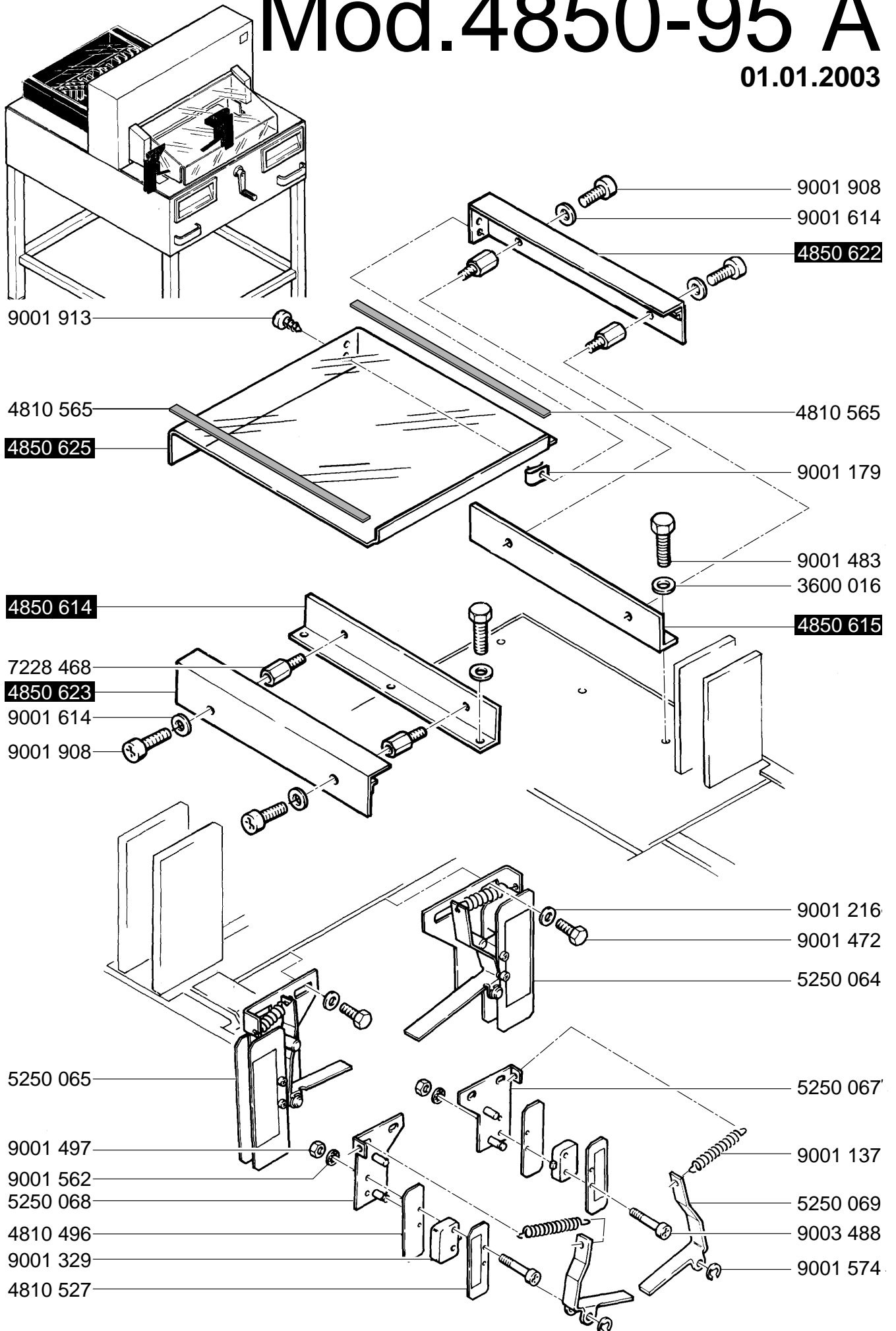

Mod.4850-95 A

01.01.2003

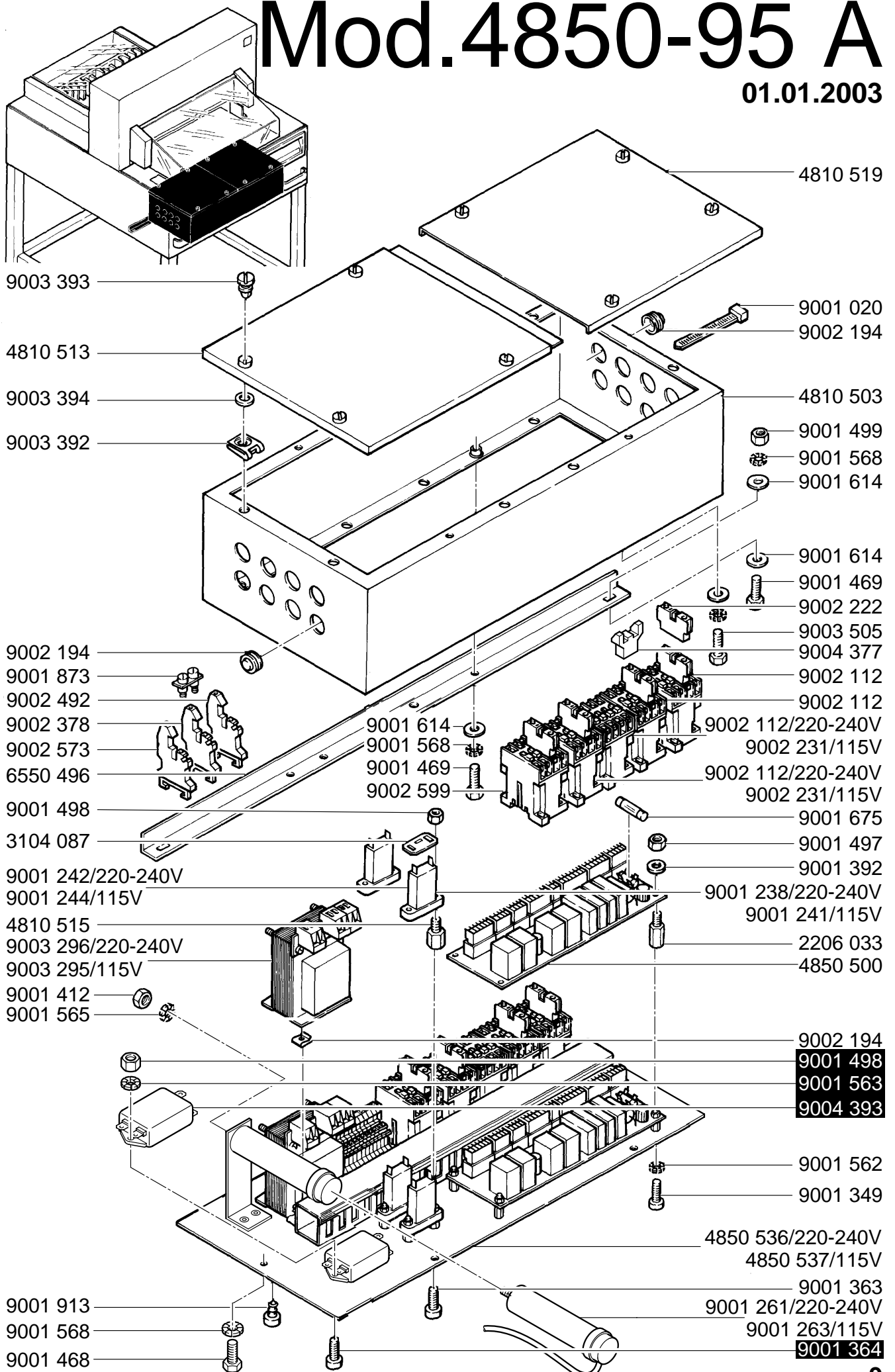

Mod.4850-95 A

01.01.2003

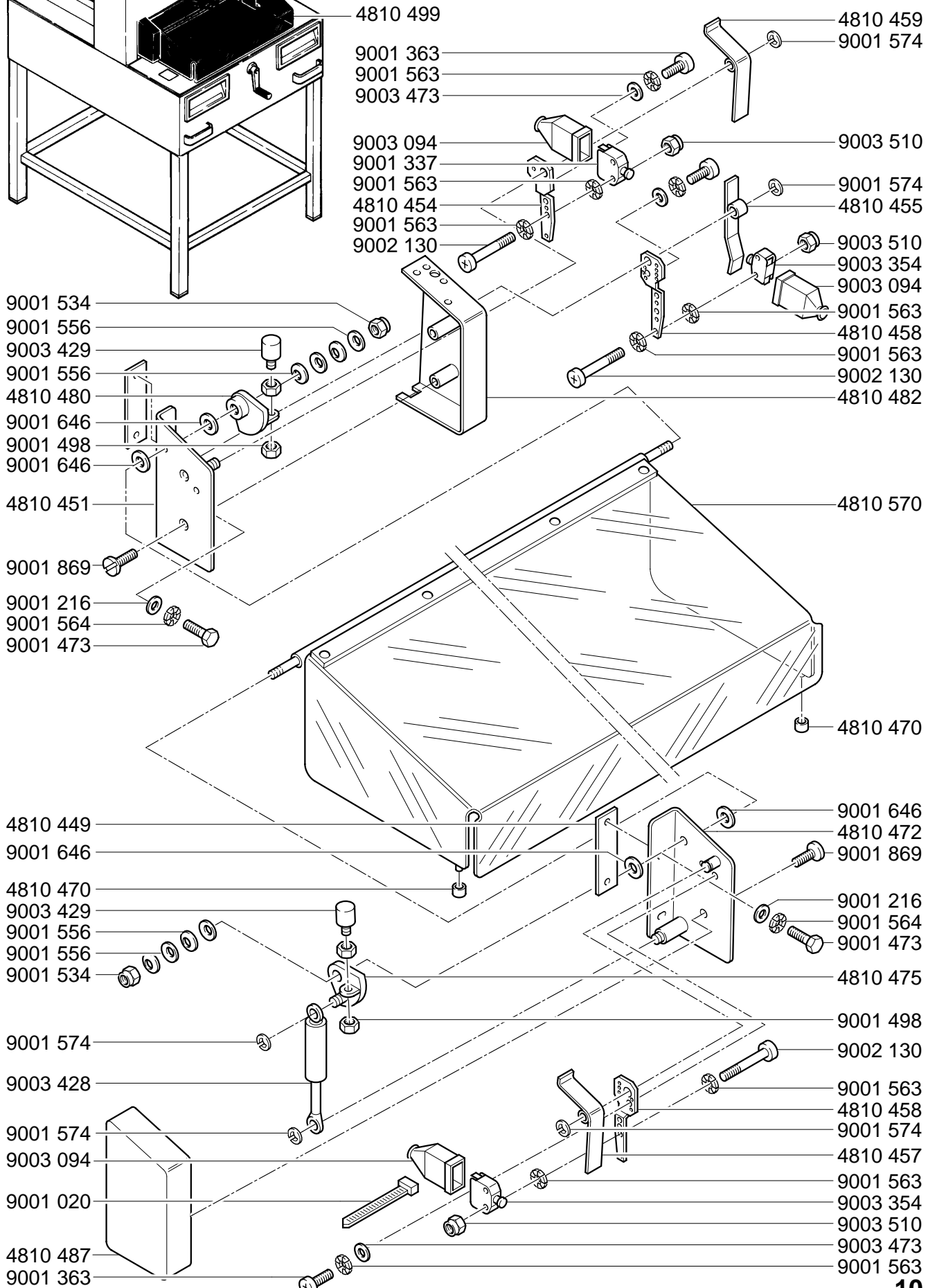
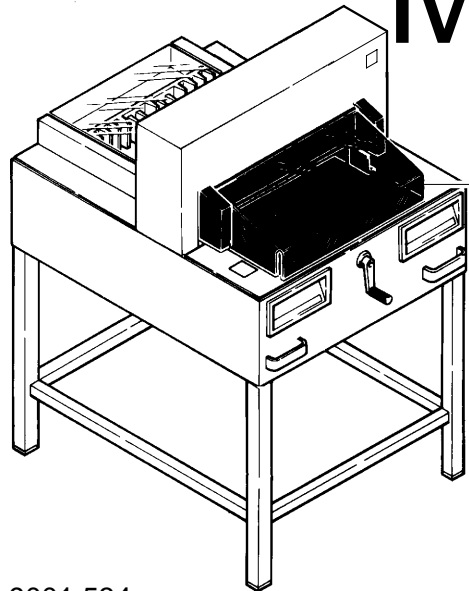

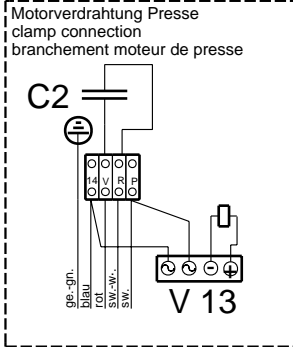
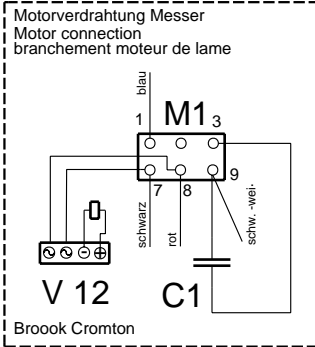
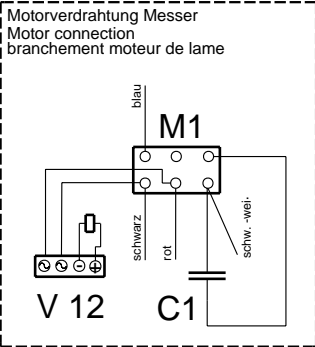
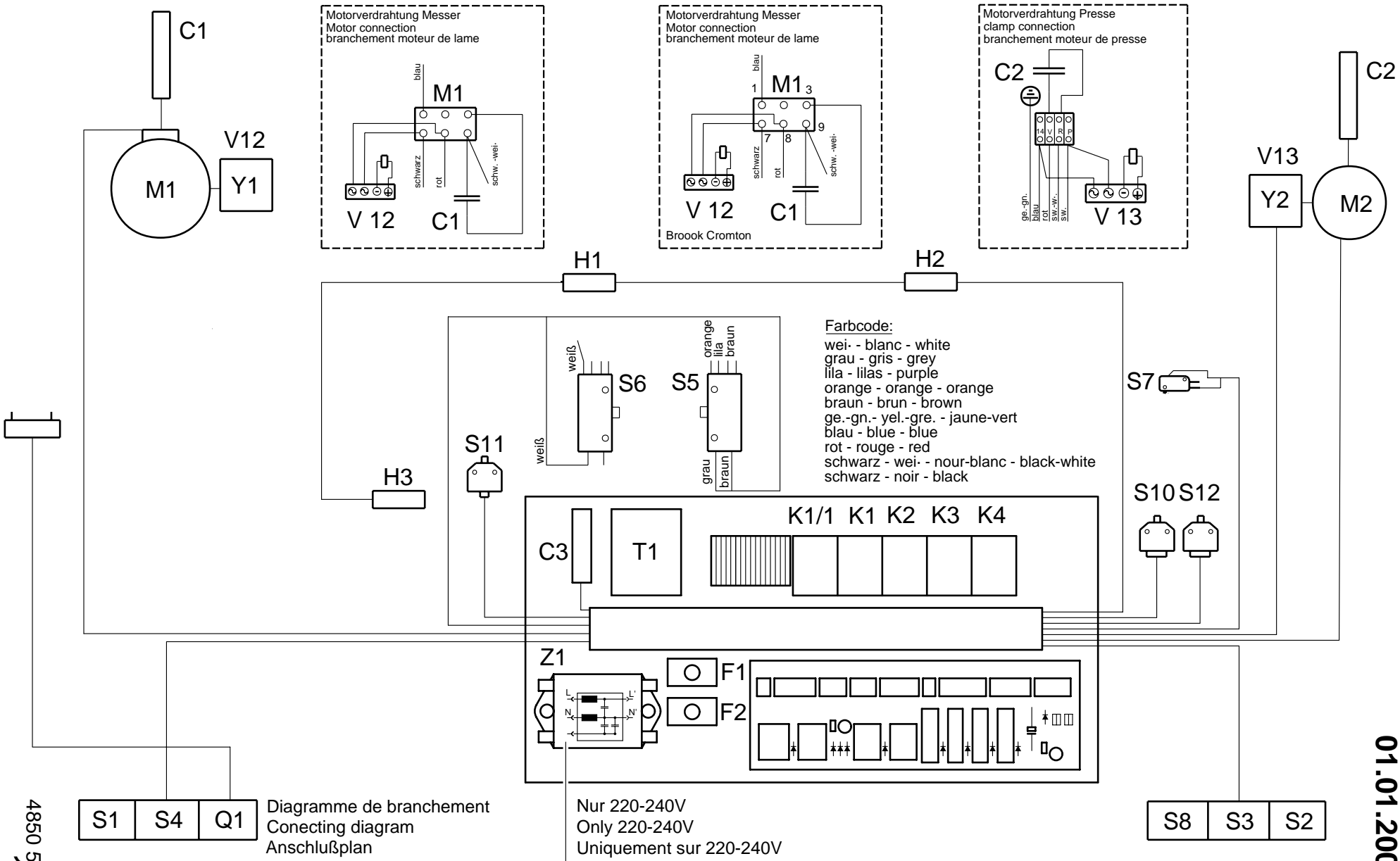

Farbcode:
 wei. - blanc - white
 grau - gris - grey
 lila - lilas - purple
 orange - orange - orange
 braun - brun - brown
 ge.-gn.-yel.-gre. - jaune-vert
 blau - blue - blue
 rot - rouge - red
 schwarz - wei. - noir-blanc - black-white
 schwarz - noir - black

Nur 220-240V
 Only 220-240V
 Uniquement sur 220-240V

S1 S4 Q1 Diagramme de branchement
 Conecting diagram
 Anschlußplan

4850 562
 11

Mod. 4850-95 A
 01.01.2003

Mod. 4850-95 A

01.01.2003

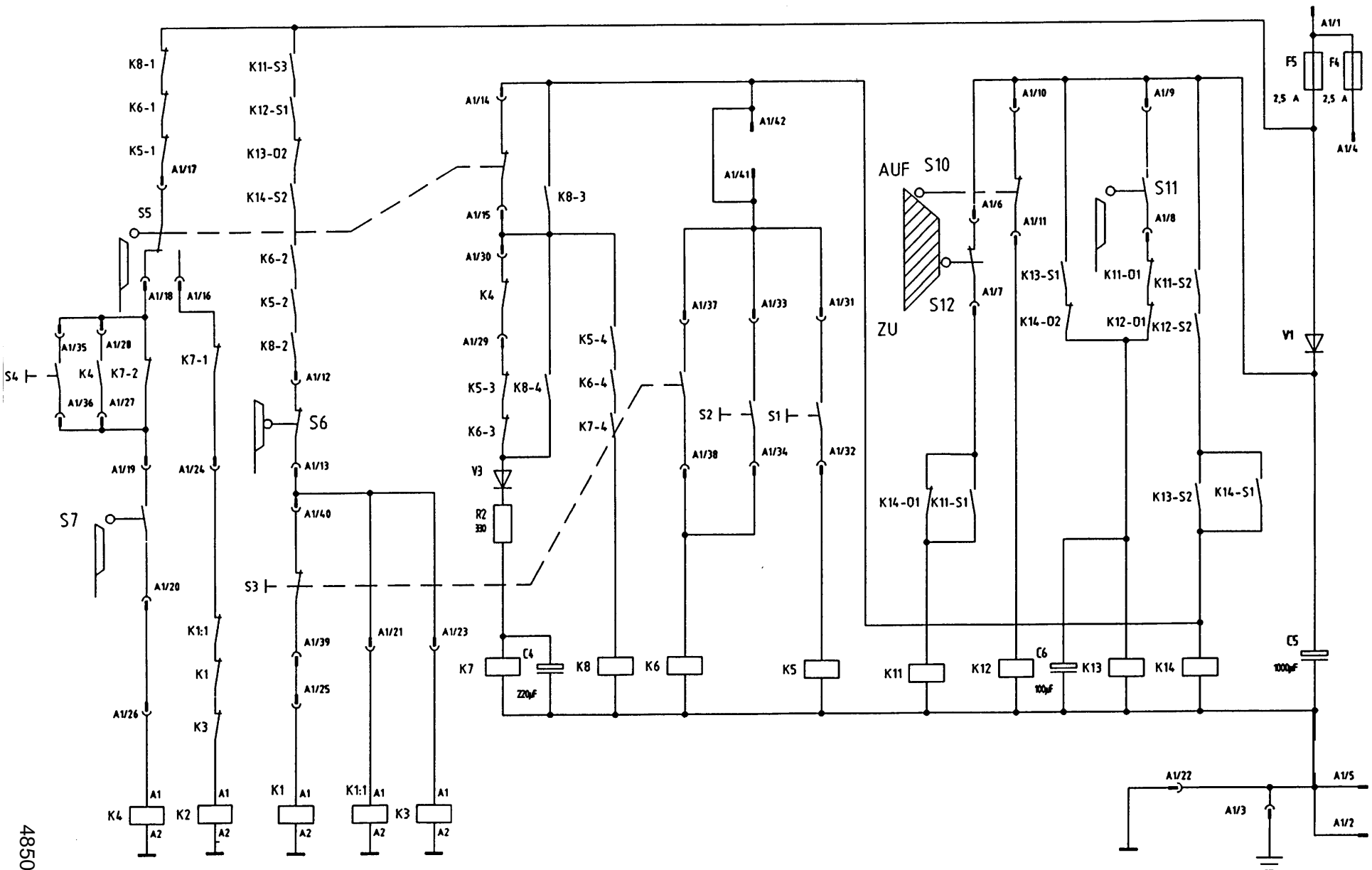

Index 4850-95, 6550-95

Code	Deutsch	English	Francais	Holländisch	Italiano	Espanol
A 1	Platine Steuerung	PCB - control	Platine de commande	Stuurprint	Scheda controllo	Placa de control
C 1	Kondensator	Capacitor	Condensateur	Condensator	Condensatore	Condensador
C 2	Kondensator	Capacitor	Condensateur	Condensator	Condensatore	Condensador
C 3	Kondensator	Capacitor	Condensateur	Condensator	Condensatore	Condensador
C 4	Kondensator	Capacitor	Condensateur	Condensator	Condensatore	Condensador
C 5	Kondensator	Capacitor	Condensateur	Condensator	Condensatore	Condensador
C 6	Kondensator	Capacitor	Condensateur	Condensator	Condensatore	Condensador
F 1	Überlastschutz Messer	Knife overload	Disjoncteur lame	Overbel. schakelaar mesm.	Interruttore sovraccarico lama	Disyuntor estribo cuchilla
F 2	Überlastschutz Presse	clamp overload	Disjoncteur presse	Overbel. schakelaar persm.	Interruttore sovraccarico pressino	Disyuntor estribo prensa
F 4	Sicherung	Fuse	Fusible	Zekering	Fusibile	Fusible
F 5	Sicherung	Fuse	Fusible	Zekering	Fusibile	Fusible
H 1	Schnittandeut	Cutting line light	Ampoule ligne de coupe	Snijlijn-verlichting	Inticatore taglio	Luz línea de corte
H 2	Schnittandeut	Cutting line light	Ampoule ligne de coupe	Snijlijn-verlichting	Inticatore taglio	Luz línea de corte
H 3	Skalenbeleuchtung	Pilot light	Ampoule vernier	Schaal-verlichting	Spia di controllo	Luz piloto
K 1	Schütz Messer ab	Knife-down contactor	Contact. descente de lame	Relais-mes omlaag	Interruttore autom. discesa lama	Contactor bajada cuchilla
K 1/1	Schütz Messer ab	Knife-down contactor	Contact. desconte de lame	Relais mes omlaag	Interruttore autom. discesa lama	Contactor bajada cuchilla
K 2	Schütz Messer auf	Knife-up contactor	Contact. remontée de lame	Relais-mes omhoog	Interruttore autom. risalita lama	Contactor subida cuchilla
K 3	Schütz Presse ab	Clamp-down contactor	Contact. descente presse	Relais pers omlaag	Interrutt. autom. discesa pressino	Contactor bajada prensa
K 4	Schütz Presse auf	Clamp-up contactor	Contact. remontée presse	Relais pers onhoog	Interrutt. autom. risalita pressino	Contactor subida prensa
K 5	Relais Taster links	Relay push button left	Relais touche gauche	Relais drukknop links	Relais pulsante sinistro	Relé botón izquierdo
K 6	Relais Taster rechts	Relay push button right	Relais touche droite	Relais drukknop rechts	Relais pulsante destro	Relé botón derecho
K 7	Relais Verzögerung	Time-delay relay	Relais retard	Vertragingsrelais	Relais de ritardo	Relé de atraso
K 8	Relais Schnittwiederholung	Relay Cutting repetition	Relais répétition de coupe	Relais-snijgangherhaling	Relais riperizione taglio	Relé repitiación corte

Index 4850-95, 6550-95

-2-

K 11	Sicherheitsrelais Klappe	Relay saftey flap	Relais volet de sécurité	Veiligheidsrelaiskap	Relais coperchio sicurezza	Relé tapa de seguridad
K 12	Sicherheitsrelais Klappe	Relay saftey flap	Relais volet de sécurité	Veiligheidsrelaiskap	Relais coperchio sicurezza	Relé tapa de seguridad
K 13	Sicherheitsrelais Klappe	Relay saftey flap	Relais volet de sécurité	Veiligheidsrelaiskap	Relais coperchio sicurezza	Relé tapa de seguridad
K 14	Sicherheitsrelais Klappe	Relay saftey flap	Relais volet de sécurité	Veiligheidsrelaiskap	Relais coperchio sicurezza	Relé tapa de seguridad
M 1	Antriebsmotor Messer	Cutting motor	Moteur lame	Snijmotor	Motore lama	Motor de corte
M 2	Antriebsmotor Presse	Clamp motor	Moteur presse	Persbalkmotor	Motore pressino	Motor prensa
Q 1	Hauptschalter	Main switch	Interrupteur principal	Hoofdschakelaar	Interruttore a chiave	Interruptor principal
R 2	Widerstand	Resistor	Résistance	Weerstand	Resistenza	Resistencia
S 1	Taster Messer + Presse	Push button knife and clamp	Touche de commande lame + presse	Drukknop mes + persbalk	Pulsante lama + pressino	Botón de la cuchilla + prensa
S 2	Taster Messer + Presse	Push button knife and clamp	Touche de commande lame + presse	drukknop mes + persbalk	Pulsante lama + pressino	Botón de la cuchilla + prensa
S 3	Taster Presse ab	Push button clamp down	Touche de comande descente presse	Drukknop persbalk omlaag	Pulsante discesa pressino	Botón bajada prensa
S 4	Taster Presse auf	Push button clamp up	Touche de commande presse remontée	Drukknop persbalk omhoog	Pulsante risalita pressino	Botón subida prensa
S 5	OT-Stopschalter Messer	Switch knife top	Arrêt lame haut	Schakelaar mes boven	Fermo lama alto	Detención cuchilla arriba
S 6	UT-Stopschalter Messer	Switch knife bottom	Arrêt lame bas	Schakelaar mes beneden	Fermo lama basso	Detención cuchillaabajo
S 7	OT-Stopschalter Presse	Switch clamp on top	Arrêt presse Haut	Schakelaar persbalk boven	Fermo pressino alto	Detención prensa arriba
S 8	Schaltenschloß	Key switch	Contacteur á clé	Sleutelschakelaar	Interruttore a chiave	Llave del interruptor
S 10	Sicherheitsschalter Klappe	Switch saftey flap	Micro-contactvolet de sécurité	Veiligheidsschakelaar kap	Interruttore coperchio sicurezza	Interruptor tapa de seguridad
S 11	Sicherheitsschalter Klappe	Switch saftey flap	Micro-contact volet de sécurité	Veiligheidsschakelaar kap	Interruttore coperchio sicurezza	Interruptor tapa de seguridad
S 12	Sicherheitsschalter Klappe	Switch saftey flap	Micro-contact volet de sécurité	Veiligheidsschakelaar kap	Interruttore coperchio sicurezza	Interruptor tapa de seguridad
T 1	Transformator	Transformer	Transformateur	Transformator	Trafoformatore	Transformador
V 1	Diode	Diode	Diode	Diode	Diodo	Diode
V 2	Diode	Diode	Diode	Diode	Diodo	Diode

Index 4850-95, 6550-95

V 3	Diode	Diode	Diode	Diode	-3-	Diode
V 12	Gleichrichter Bremse	Rectifier	Redresseur frein	Gelijkrichter-rem	Raddrizzatore	Rectificador
V 13	Gleichrichter Bremse	Rectifier	Redresseur frein	Gelijkrichter-rem	Raddrizzatore	Rectificador
Y 1	Bremse Messermotor	Brake, knife motor	Frein moteur de lame	Rem-snijmotor	Freno motore lama	Freno motor cuchilla
Y 2	Bremse Pressmotor	Brake, clamp motor	Frein moteur de presse	Rem-persmotor	Freno motore pressino	Freno motor prensa
Z 3	Drossel	Throttle	Self	Ontstoorspoel	Valvola di regolazione	Válvula reguladora

Mod. 4850-95 A
 01.01.2003

Mod.4850-95 A

01.01.2003

